



Ernest H Hill Ltd
Manufacturers of Fluid Transfer and
Lubrication Equipment Since 1841

Equipment Catalogue





Manufacturers of Fluid Transfer and Lubrication Equipment Since 1841



Ernest H. Hill Limited was established as an engineering and manufacturing company in 1841. Founded and still base in Sheffield, England, a name synonymous with fine quality and sound engineering practice. Hill have been involved in the innovation, design and manufacture of fluid transfer equipment for the last 165 years.

Amongst the early products, under the long established trademark Nesthill, was an air compressor pump designed for a veterinary surgeon John Boyd Dunlop which was developed to inflate the prototype pneumatic tyre he had invented for his bicycle.

In 1907, the company was one of the earliest to incorporate as a Limited Liability Company. Now located in a modern industrial unit in Sheffield, the commitment to quality and service is as high as ever. Our equipment is now designed and created using the latest 3D mechanical design and modelling software. Production is controlled by the latest high performance resource management software. Logistics and communication are effected using state of the art electronic commerce technology.

Responsive and pro-active in research and development, Hill are able to react quickly to market changes. Supporting a comprehensive range of fluid transfer products that are exported to every corner of the world; our current markets are as diverse as they have always been. Today, Hill fluid transfer equipment, much of which is branded in the customer's image is ubiquitous in automotive and industrial lubrication, petrochemical, industrial, agricultural and aerospace fluid transfer situations.

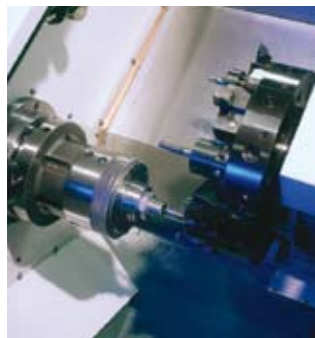

Contents



HAND PUMPS	4-6
PUMP ADAPTERS	6
AIR OPERATED PUMPS	7
PUMP KITS	8-9
DIAPHRAGM PUMPS	10
ELECTRIC PUMPS	11
FUEL DISPENSERS	12-13
REEL POSTS	14-15
HOSE REELS	15
HOSE REEL KITS	16
FLUID MANAGEMENT SYSTEMS	16
FLOW METERS & OIL GUNS	18-19
FILL CABINETS & DRIP TRAYS	20
WASTE OIL UNITS	21-22
TROLLEYS	23
MOBILE LUBRICATION UNITS	24
GREASE UNITS	25
GENERAL EQUIPMENT	26-28
PIPE FITTINGS	29



Hand Pumps

The Hill range of hand pumps is extensive and the following examples reflect only the most popular models. A huge variety of options are available, including hose kits and adapters which enable fitment to most known drums. Over many years Hill have developed specialist pumps to cope with a variety of different fluids. Contact Hill Sales for more details.



SERIES 950 LEVER PUMP

For transferring various fluids from tanks and drums. 2" BSP fitting with telescopic uptake pipe 400 - 915mm Discharge approximately 0.3 Ltr/stroke

Shipping dimensions (mm) 530 x 240 x 115 Weight 1.3 kg

Product Code	Description
P950-AAA	Lever Pump - Nitrile Seals
P950-AVT	Lever Pump - Viton Seals
P950-EVT	Lever Pump - EPDM Seals
I950-001	Lever Pump - Food Grade FDA approved

Available in Seven Colours

925 TRANSFER PUMP

For transferring various fluids from small and large drums. 2" BSP fitting with telescopic uptake pipe 400 - 915mm Discharge approximately 0.25 Ltr/stroke Can be used as a siphon.

Shipping dimensions (mm) 530 x 195 x 120 Weight 1.4 kg

Product Code	Description
P925-AAA	Transfer Pump

960 SERIES 20/25 LTR DRUM PUMP

For transferring most types of oil, non-corrosive fluids and tyre sealant. Discharge approximately 0.1 Ltr/stroke via 1.5m hose with positive shut off valve Drum trolley and keg lid also available

Shipping dimensions (mm) 550 x 270 x 115 Weight 1.4 kg

Product Code	Description
F960-JAA	Gear Oil Pump 2" BSP

2098 STAINLESS STEEL PUMP

Stainless Steel chemical pump. Manufactured from 316 Grade Stainless Steel with PTFE seals. Fully height adjustable collar. Will fit any drum from 10 to 208 Ltr Discharge approximately 0.125 Ltr/stroke

Shipping dimensions (mm) 750 x 215 x 90 Weight 2.2 kg

Product Code	Description
2098-001	Stainless Steel Pump



Hand Pumps

1470 ROTARY PUMP

For transferring oils and other non corrosive fluids from tanks and drums.

Easily primed, constant flow of 30 Ltr/min 2" BSP fitting with telescopic uptake pipe 750 - 1200mm 360° drum alignment secured by lockring.

Shipping dimensions (mm) 785 x 150 x 150 Weight 2.8 kg

Product Code	Description
PI470-AAA	Rotary Pump



HIGH VOLUME ROTARY FUEL PUMP

Fully reversible Rotary Fuel Pump. Suitable for low viscosity fluids like gasoline and kerosene. High volume output using a system of gear driven rotary vanes. Discharge approximately 80 Ltr/min

Shipping dimensions (mm) Weight kg

Product Code	Description
06R70036	High Volume Rotary Pump



ADBLUE PUMP

For transferring AdBlue and DEF from tanks and drums. Discharge approx. 330mls per stroke 2 inch BSP fitting, anti drip nozzle, telescopic uptake pipe. 400 - 915mm Polypropylene with AdBlue seal options. Available with many different adapters to fit any drum. Kits available upon request with AdBlue Hose

Shipping dimensions (mm) Weight kg

Product Code	Description
0950-058	AdBlue Pump



HIGH VOLUME GREASE / OIL PUMP

Suitable for 20kg and 50kg Grease kegs. Generates a pressure of >250psi

Shipping dimensions (mm) Weight kg

Product Code	Description
PI030-AAA	50kg High Volume Grease / Oil Pump
PI032-AAA	20kg High Volume Grease / Oil Pump



2081 GENERAL PURPOSE SYRINGE

Suitable for transferring a vast range of fluids. Made from strong durable polymers. Used in many industrial, agricultural and domestic situations Discharge approximately 0.2 Ltr/stroke

Shipping dimensions (mm) 750 x 150 x 50 Weight 0.6 kg

Product Code	Description
2081-001	General Purpose Plastic Syringe



Hand Pumps



970 STIRRUP PUMP

Dual action stirrup / bucket pump manufactured from brass. Mainly used for pumping water based liquids for fire fighting, spraying pesticides and insecticides in both horticultural and agricultural situations. Comes with hose, lance and spray nozzle.

Shipping dimensions (mm) Weight kg

Product Code	Description
0970-001	Stirrup Pump



2184 TYRE SEALANT PUMP

For filling tyres with tyre sealant. Pump directly from 20 / 25 litre drums into partially inflated tyres. Working pressures of 130psi and 60psi respectively. Complete with standard tyre adapter.

Shipping dimensions (mm) 550 x 270 x 115 Weight 1.3 kg

Product Code	Description
2184-002	Tyre Sealant Pump
2184-250	Tyre Sealant Pump 250ml per stroke



933 SOLVENT PUMP

For dispensing solvents and other chemicals from large or small drums. Self priming, discharge approx. 200mls per stroke. All brass construction with PTFE seals.

Shipping dimensions (mm) Weight 2.8 kg

Product Code	Description
P933-AAA	Brass Solvent Pump

Pump Adapters

Pump mounting adapters are available to suit most known closures on 20, 25 and 30 Litre drums. These can be fitted to all hand operated pumps in the Hill range.



Product Code	Description
06960-30	22. Trisure adapter
06956-02	23. US Buttress adapter
06925-26A	24. Mauser adapter
06960-22	25. 2" BSP adapter
06960-21	26. Plysu / Pressneck adapter
062043-01	29. Stolz 60IF Lockring
062051-04	31. Stolz Lockring
062074-01	32. Rieke Lockring
05925-B1	34. Berg adapter
05934-05	36. 2" BSP x DIN 61/31 adapter
06925-B3	39. 2" BSP x 64mm adapter
06R22009	40. DIN 51 adapter
06470-15	2" BSP Lockring
05934-07	DIN 71 adapter

Air Operated Pumps

AFI 1:1 AIR PUMP

Shipping Dimensions (mm) 535 x 335 x 105 Weight 2.2 kg

Product Code	Description
PI050-AFI	AFI Pump with Nitrile Seals
PI050-AVT	AFI Pump with Viton Seals
PI050-EVT	AFI Pump with EPDM Seals



1:1 AIR PUMPS

Shipping dimensions (mm) [06R61001A - 670 x 100 x 80] ; [06R1008A - 1380 x 100 x 80]

Product Code	Description
06R61001A	1:1 Stub Pump 220mm Uptake Weight 3.6 kg
06R61008A	1:1 Drum Pump 915mm Uptake Weight 5.5 kg



3:1 AIR PUMPS

Shipping dimensions (mm) [06R61002A - 670 x 100 x 80] ; [06R61005A - 1370 x 100 x 80] ; [P716-CAV -]

Product Code	Description
06R61002A	3:1 Stub Pump 220mm Uptake Weight 3.4 kg
06R61005A	3:1 Drum Pump 915mm Uptake Weight 5 kg
P716-CAV	2:1 Stainless Steel Pump Weight 6.5 kg



HV AIR PUMPS

Shipping dimensions (mm) [06R61016 - 680 x 90 x 80] ; [06R61017 -]

Product Code	Description
06R61003	3:1 H.V. Stub Pump Weight 3.5 kg
06R61009	3:1 H.V. Drum Pump Weight 5.3 kg
06R61004	5:1 H.V. Stub Pump Weight
06R61010	5:1 H.V. Drum Pump Weight



50:1 GREASE PUMPS

Shipping dimensions (mm) [06R70019 - 875 x 120 x 80] ; [06R70020 - 1140 x 120 x 80] ; [06R70014 - 1320 x 110 x 80]

Product Code	Description
06R70019	50:1 Grease Pump for 20kg Weight 6.9 kg
06R70020	50:1 Grease Pump for 50kg Weight 8.2 kg
06R70014	50:1 Grease Pump for 180kg Weight 9.1 kg



Pump Kits



HAND OPERATED AdBlue / DEF / Urea PUMP KITS

Product Code	Description
0950-085	Hand Operated Lever Pump with Hose Kit



AIR OPERATED AdBlue / DEF / Urea PUMP KITS

Product Code	Description
1050-015	Air Operated Pump
Z1050-003	Hose Kit c/w Nozzle
Z1050-004	Hose Kit c/w meter & Nozzle



PUMP SELECTION AID

Pump Ratio	Air Inlet	Fluid Outlet	High Capacity	Med Capacity	Short Distance	Med Distance	Long Distance
1:1	1 bar	1 bar	*		*		
3:1	1 bar	3 bar		*		*	
5:1	1 bar	5 bar		*			*

Pump Kits

3:1 & 5:1 AIR PUMP TANK MOUNTING KITS

Product Code	Description
P500-CAV	3:1 Air Pump Tank Mounting kit 1.5m Delivery Hose
P501-CAV	3:1 Air Pump Tank Mounting kit 3m Delivery Hose
P766-FRL	3:1 H.V. Air Pump Tank Mounting Kit
P771-FRL	5:1 H.V. Air Pump Tank Mounting Kit



1:1 & 3:1 AIR PUMP WALL MOUNTING KITS

Product Code	Description
P741-KIT	Wall Mounting kit 1:1 Air Pump
P761-KIT	Wall Mounting kit 3:1 Air Pump

AIR MANAGEMENT KIT

Product Code	Description
Z300-CAV	Air Management Kit

1:1 & 3:1 AIR PUMPS WALL MOUNTING KIT

Product Code	Description
Z200-CAV	Wall Mounting Kit 1:1 & 3:1 Air Pumps

TANK MOUNTING KIT

Product Code	Description
Z100-CAV	Tank Mounting Kit

Diaphragm Pumps

AIR OPERATED DOUBLE DIAPHRAGM PUMPS

We have a full range of Diaphragm Pumps available, please call or e-mail for one of our Engineers to help choose the right pump for the right job.

Diaphragm Pump Size: From ¼” BSP to 3” BSP

Flow Rates: From 15 to 850 ltrs/min

Our Diaphragm Pumps and seals are made from different materials depending on the application and fluid being pumped.

Pump Body available in: Aluminium, Polypropylene, Acetyl, Cast Iron, Stainless Steel.

Diaphragms and seals: Buna (Nitrile), PTFE, TPE, Santoprene, Viton.

Pumps can also be ATEX (ExII) Rated On Request

- 30% MORE EFFICIENT AIR MOTOR
- 5X LONGER LASTING
- 20% INCREASE IN FLOW RATE



Electric Pumps

ELECTRIC PUMP SPECIFICATIONS – 240V

The Viscomat family of Electric Oil Pumps is designed to provide an effective alternative solution to pumping viscous fluids such as engine and gear oil as well as non-viscous fluid, such as hydraulic fluid, transmission fluid and 100% (non mixed) antifreeze.

Product Code	MAX FLOW RATE		PRESSURE		WEIGHT kg
	l/min	gal/min	bar	psi	
06R70085	25	6.6	6	85	14.1
06R70082	50	13.2	5	71	14.1
06R70086	9	2.4	12	170	9
06R70087	14	3.7	12	170	12.5
06R70088	9	2.4	25	355	12.5
06R70079	9	2.4	25	355	12.5



VISCOMAT VANE PUMPS

Product Code	Description
06R70085	Viscomat 70M Vane Pump
06R70082	Viscomat 90M Vane Pump



VISCO FLOWMAT GEAR PUMPS

Product Code	Description
06R70086	Visco Flowmat 200/2 Gear Pump
06R70087	Visco Flowmat 230/3 Gear Pump
06R70088	Visco Flowmat 350/2 Gear Pump



AC PANTHER 56 DIESEL PUMP

Product Code	Description
06R70191	AC Panther 56 Diesel Pump



AC PANTHER 72 DIESEL PUMP

Product Code	Description
06R70107	AC Panther 72 Diesel Pump



DC PORTABLE DIESEL PUMP

Product Code	Description
06R70126	Carry 3000 - 50 l/min



DC DIESEL BATTERY KIT MODEL

Product Code	Description
06R70093	DC Diesel Battery Kit Model

Fuel Dispensers



CARRY 3000 PORTABLE DIESEL PUMP

Carry 3000 Model
Available in 12 and 24-Volt versions.
3/4" threaded connectors on the pump body.
Switch box and fuse carrier, complete with power cables and clamps for connection to terminal strips.

Product Code	Description
06R70126	Portable Diesel Pump - 50 l/min



FUEL TRANSFER BOX KIT

This is a portable unit for transferring Diesel fuel, fitted with a pump run by a 12 V or 24 V DC electric motor. Everything you need in one handy box. Thanks to its small size, reliability and simple installation, it is specially useful when fuel must be transferred or dispensed safely having only battery power on hand, as in construction sites, on boats and in agriculture. Kit complete with pump, on/off switch, 4mtr 3/4" hose, 2mtr battery cable and clips, connectors and filter.

Product Code	Description
06R70203	Fuel Transfer Box Kit - 45 l/min



CUBE 56 FUEL TRANSFER UNIT

Delivery rate: up to 56 l/min.
Pumping unit: self-priming rotary vane type with by-pass valve.
Direct drive by a IP55 motor with thermal overload protection AC version.
Meter: volumetric nutating disc type. Large 3 digits re-settable register and 6 digits totalizer.
Nozzle and hose: AUTOMATIC type.
Nozzle HANGER with on/off pump switch.
4 m reinforced 3/4 diameter diesel hose with integral static.
Cabinet: anti-corrosive treated steel panels, painted finish.
Options: 110/120 VAC 60 HZ motor.

Product Code	Description
06R70145	Cube 56 Fuel Transfer Unit - 56 l/min



CUBE 70 FUEL TRANSFER SYSTEM

The CUBE 70 fuel pump offers a new design and new performance specifications to satisfy those customers involved in the private distribution of diesel fuel. CUBE 70 is a compact, light pump that allows refuelling at flow rates up to 70 l/min under conditions of complete operator safety. Equipped with an easy to use, high-precision mechanical meter that can even be calibrated on-site. Its housing painted for exterior use with a stainless steel cover provides a nozzle holder with lever on-off switch and automatic pump turn-off. CUBE 70 is extremely versatile and can be installed directly on a wall or to an existing structure with anchor screws or directly to the drum with a 2" quick connect. CUBE 70 can also be integrated with a support base and column for attaching to the ground. The column can be used to house the suction tubing and the electric power cables. Flow-rate up to 70 l/min

Product Code	Description
06R70100	Cube 70 Fuel Transfer System - 70 l/min

Fuel Dispensers



CUBE 70 MC FUEL MANAGEMENT SYSTEM

CUBE 70 is a compact, light unit for refuelling at flow rates up to 70 l/min. Fast, safe precise and easy to maintain, they are equipped with an electronic control unit (MC) that allows only authorised personnel to dispense fuel and provides rational control by recording and storing the quantities dispensed by each user. The MC system allows pre-selecting the amount to be dispensed, with automatic pump stop. CUBE 70 is extremely versatile and can be installed directly on a wall or to an existing structure with anchor screws or directly to the drum with a 2" quick connect. CUBE 70 can also be integrated with a support base and column for attaching to the ground. Performance Specifications: Flow-rate up to 70 l/min

Product Code	Description
06R70149	Cube 70 MC Fuel Management System - 70 l/min



AC DRUM TRANSFER UNIT

The drum line has been designed for an easy connection to the 2" quick coupling of the drum or tank. They can be fitted with or without meter k33. Standard equipment: self-priming pump, positive-displacement type, 2" quick coupling, 4 mt. delivery hose, nozzle self 2000, intake telescopic tube. Automatic nozzle and other accessories are available on request.

Product Code	Description
06R70153	AC Drum Transfer Unit - 80 l/min



PICO DC DRUM TRANSFER UNIT

The Pico drum line has been designed for an easy connection to the 2" quick coupling of the drum or tank. They can be fitted with or without meter k24. Standard equipment: self-priming pump, positive-displacement type, 2" quick coupling, 4 mt. delivery hose, nozzle self 2000, intake telescopic tube. Automatic nozzle and other accessories are available on request.

Product Code	Description
06R70204	Pico DC Drum Transfer Unit - 30 l/min

Reel Posts



STANDARD REEL POSTS

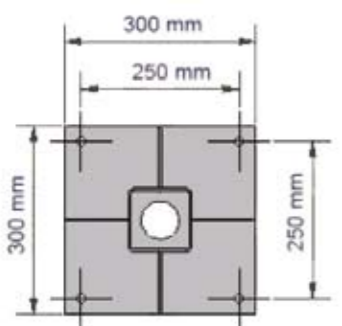

Base Footprint

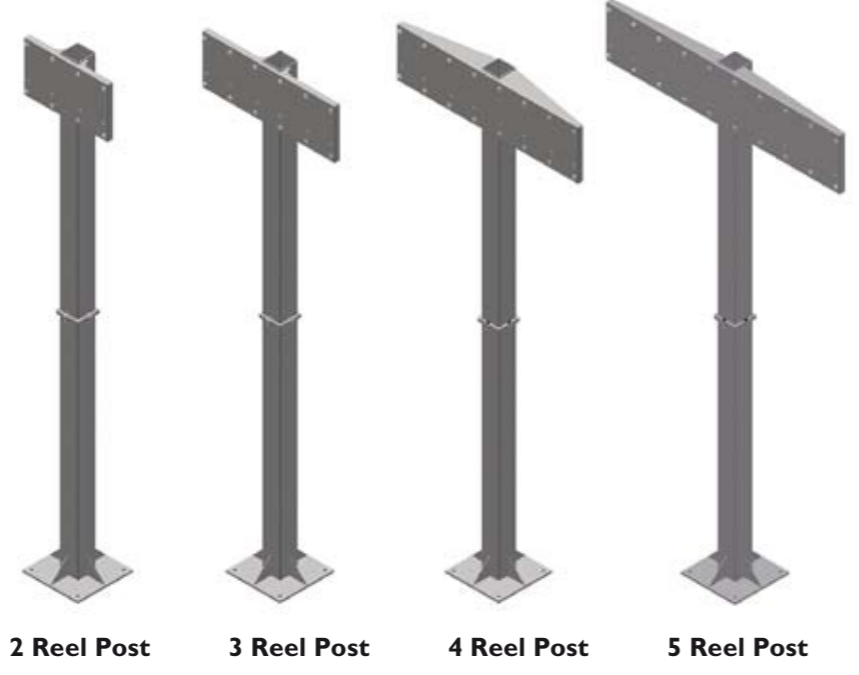

2 Reel Post 3 Reel Post 4 Reel Post 5 Reel Post

Reel Posts

ANCILLARY EQUIPMENT

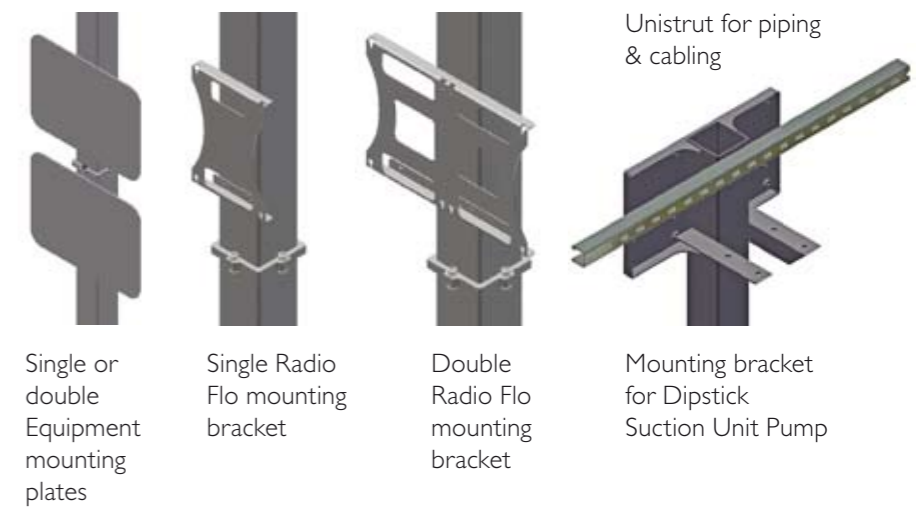

Single or double Equipment mounting plates Single Radio Flo mounting bracket Double Radio Flo mounting bracket Unistrut for piping & cabling Mounting bracket for Dipstick Suction Unit Pump

2164 REEL GANTRY

Suitable for 6 or more hose reels



REEL MOUNTING PLATE

For mounting hose reels to existing building steel columns

Hose Reels

CASED HOSE REELS

Shipping dimensions (mm) 580 x 560 x 200

Product Code	Description
F2032-AAA	Cased Hose Reel 1/2" dia x 10m lg Weight 15.5 kg
F2032-CAA	Water / Air Hose Reel 3/8" dia x 10m lg Weight 13 kg
F2032-WOO	Waste Oil Suction Reel x 5m lg



OPEN HOSE REELS & AIR HOSE REELS

Product Code	Description
F2033-AAA	Open Hose Reel 1/2" dia x 10m lg
F2033-BAA	Open Hose Reel 1/2" dia x 15m lg
F2033-DAA	Open Hose Reel 1/2" dia x 20m lg
06R70035	Compact Air Reel

Hose Reel Kits



2100-004 2100-003

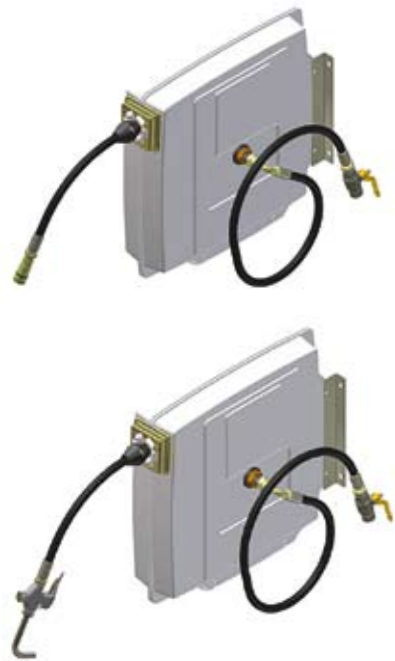

OIL REEL

Product Code	Description
2032-007	Oil Reel c/w Y Strainer & Ball Valve (supplied without hose end oil gun)

AIR REEL

Product Code	Description
2032-008	Air Reel c/w 3/8" Q.R. Carrier & Ball Valve

WATER REEL

Product Code	Description
2032-009	Water Reel c/w Water Gun & Ball Valve



Computer Based Fluid Management

BULK TANK AND FLUID MANAGEMENT SYSTEMS

Computer based workshop fluid and bulk tank management system that utilises the very latest technology, offering complete security and accountability for all oil and fluid dispensing. Bulk tank management system with high and low level alarms. Contact Sales department for leaflet or further details.



Auxiliary Equipment

RECHARGEABLE LED TOUGHLAMP

Product Code	Description
06R25037	Rechargeable LED Toughlamp

12V REEL C/W INSPECTION LAMP

Product Code	Description
06R25021	12V Reel c/w Inspection Lamp

OIL GUN C/W SWIVEL & NON DRIP FLEXI NOZZLE

Product Code	Description
2100-003	Oil Gun c/w swivel & non drip flexi nozzle

COMMERCIAL METER & OIL GUN

Product Code	Description
2100-004	Commercial meter & Oil Gun c/w swivel & non drip flexi nozzle

WATER GUN 3/8" BSP

Product Code	Description
06R70064	Water Gun 3/8" BSP

K500 PRESET BATCH METER

Product Code	Description
06R62006	K500 Preset Batch meter

GREASE GUN WITH 1/4" BSP Z SWIVEL

Product Code	Description
06R70016	Grease Gun with 1/4" BSP Z Swivel

Air Line Equipment

1/4" BSP FILTER REGULATOR UNIT

Product Code	Description
06R24046	1/4" BSP Filter Regulator Unit

MOUNTING BRACKET FOR 06R24046

Product Code	Description
06R24047	Mounting Bracket for 06R24046

7 BAR REGULATOR 1/4" BSP

Product Code	Description
06R24001	7 bar Regulator 1/4" BSP

PRESSURE GAUGE 0 - 10 BAR 50MM DIA X 1/8" BSP

Product Code	Description
06R24002	Pressure Gauge 0 - 10 bar 50mm dia x 1/8" BSP

1/2" BSP PRESSURE RELIEF VALVE

Product Code	Description
06R20079	1/2" BSP Pressure Relief Valve

Digital Flowmeter

K400 DIGITAL FLOWMETER

Product Code	Description
06R62001	K400 Digital Flowmeter

K24 CHEMICAL METER

Product Code	Description
06R62023	K24 Chemical Meter

K400 DIGITAL FLOWMETER WITH PROTECTION RING

Product Code	Description
ZI050-DIU	K400 Digital Flowmeter c/w Rubber Protection Ring



Offset Fill Cabinets

Offset Fill Cabinets
Supplied with Drip Pan
and locking door



2159-001 illustrated

OFFSET FILL CABINETS

Shipping dimensions (mm) 760 x 450 x 410

Product Code	Description
2159-001	Offset Fill Cabinet 3 way side entry Weight 38 kg
2159-00	Offset Fill Cabinet 2 way side entry Weight 34 kg
2159-003	Offset Fill Cabinet 3 way top entry Weight 40 kg
2159-004	Offset Fill Cabinet 2 way top entry Weight 36 kg
2159-005	Offset Fill Cabinet 3 way back entry Weight 38 kg
2159-006	Offset Fill Cabinet 2 way back entry Weight 34 kg

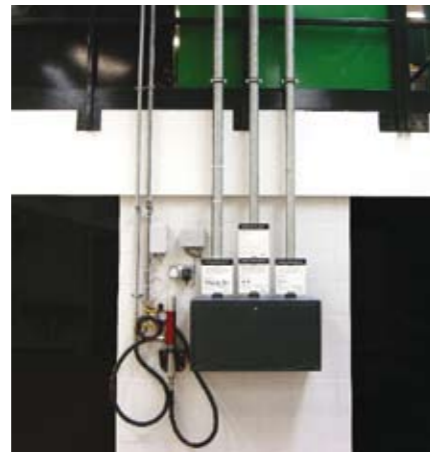

Wall Mounted Drip Trays



WALL MOUNTED DRIP TRAY

Shipping dimensions (mm) 725 x 625 x 335 Weight 13.5 kg

Product Code	Description
2133-002	Wall mount drip tray - Black
2133-003	Wall mount drip tray - White
2133-005	Wall mount drip tray - Grey RAL 7016

DRIP PANS

Shipping dimensions (mm) 195 x 160 x 75 Weight 1.3 kg

Product Code	Description
F973-AAA	Drip Pan - Black
0973-002	Drip Pan - White

Waste Oil Units



All Hill Waste Oil Units are available in several different colours and can be adapted to suit individual needs.

2153 MOTOR CYCLE DRAINER UNIT WASTE OIL COLLECTION UNIT

Low height unit for use with motor cycle work lifts. Collection hopper is adjustable for both height and angle. Available with 1:1 Air pump attached for emptying unit or quick release coupling for draining by independent pump. 80 Ltr capacity tank.



2153-003
Weight 22kg

2153-004
Weight 27kg

Shipping dimensions (mm)
1175 x 825 x 335
Weight 45 kg



0951-500

Shipping dimensions (mm)
1175 x 755 x 360
Weight 36 kg



F951-BLK

951 LOW PROFILE WASTE OIL UNIT

80 Ltr capacity, commercial vehicle waste oil unit. Complete with 1:1 Air pump for draining or with a quick release coupling for use with independent pump.

Waste Oil Units

F949-AAA



949 PIT WASTE OIL COLLECTOR

95 Ltr Capacity
Adjustable mounting arms 1030 to 1450mm with roller castors.
Quick release coupling for draining by independent pump.
Can be supplied with mounted 1:1 air pump.

Shipping dimensions (mm) 810 x 800 x 500 Weight 40 kg



2200-004 WASTE OIL COLLECTION UNIT

Complete with heavy duty 1:1 air operated discharge pump.
95 litre tank with height adjustable hopper.
Quick release couplings both for air inlet and waste oil discharge.
Fitted with integral Air Regulator.
Available in various colours.

Shipping dimensions (mm) 1200x760x700 Weight 45 kgs



2200-020 WASTE OIL COLLECTION UNIT

95 Ltr tank capacity with height adjustable hopper Complete with 1:1 Air pump for draining unit, quick release air and waste oil couplings.

Shipping dimensions (mm) 1200x760x700 Weight 40 kg



2200-002 WASTE OIL COLLECTION UNIT

Complete with quick release coupling for use with optional wall mounted pump. See Pump Kits.
95 litre tank with height adjustable hopper.
Level Indicator to prevent overfill.
Available in various colours.

Shipping dimensions (mm) 1200x760x700 Weight 36 kgs



2114 DIAPHRAGM PUMP SUCTION WASTE OIL COLLECTION UNIT

Fitted with diaphragm pump inside the tank for dipstick suction. (supplied with full range of probes) Very strong suction to empty vehicle via dipstick tube and very strong discharge action to empty tank when full. Automatic shut-off when finished.

Shipping dimensions (mm) 1180 x 780 x 690 Weight 48 kg

Trolleys



208 LTR DRUM TROLLEY

Shipping dimensions (mm) 930 x 790 x 220 Weight 20 kg

Product Code	Description
2129-008	208 Ltr Drum Trolley



60 LTR DRUM TROLLEY

Shipping dimensions (mm) 1010 x 555 x 445 Weight 8.3 kg

Product Code	Description
F1003-AAA	60 Ltr Drum Trolley



CHAIN TROLLEY

Shipping dimensions (mm) 990 x 370 x 315 Weight 6.5 kg

Product Code	Description
F985-BLK	Chain Trolley



20 - 25 LTR DRUM TROLLEY (FLAT PACK)

Suitable for any 20 - 25 litre drum.
Flat packed for easy shipment (120 will fit on a euro pallet.)
All tools for assembly are supplied

Shipping dimensions (mm) 550 x 270 x 115 Weight 3.7 kg

Product Code	Description
2113-001	20 - 25 Ltr Drum Trolley (Flat Pack)

Mobile Lubrication Units



208 LTR DRUM TROLLEY

Shipping dimensions (mm) Weight kg

Product Code	Description
2129-005	208 Ltr Drum Trolley c/w 3:1 Air Pump 3 mtr Hose and Oil Gun with Meter
2129-006	As 2129-005 with 10 mtr hose reel and meter
2129-007	As above without meter (not illustrated)



60 LTR OIL DISPENSER

Shipping dimensions (mm) 1020 x 560 x 440 Weight kg

Product Code	Description
2092-002	60 Ltr Oil Dispenser c/w 3:1 Air Pump 3 mtr Hose and Oil Gun with Meter



2026 MOBILE DISPENSER 105 LITRE

Suitable for storing and transporting most types of fluid in garage and workshop environments. Ideal for antifreeze. Heavy duty steel construction.

Complete with AFI air operated pump, 2m hose and positive on / off tap. Available in various colours.

Product Code	Description
F2026-LUB	95 Ltr Dispensing Unit - Black



SERIES 960 GEAR OIL UNITS

These units are available for all known drums and can be supplied with any length of hose to suit your application.

Shipping dimensions (mm) Weight 5 kg

Product Code	Description
F960-CAS	Gear Oil Unit with 2" BSP and Trisure Adapters

Mobile Grease Units



180KG AIR OPERATED GREASE UNIT

Shipping dimensions (mm) Weight 42 kg

Product Code	Description
G2129-001	180kg Air operated Grease Unit



50KG AIR OPERATED GREASE UNIT

Shipping dimensions (mm) 1030 x 570 x 450 Weight kg

Product Code	Description
G999-BIR	50kg Air operated Grease Unit



20KG AIR OPERATED GREASE UNIT

Shipping dimensions (mm) Weight kg

Product Code	Description
G999-001	20kg Air operated Grease Unit

Hand Operated Grease Units



12.5 KG GREASE UNIT >5000PSI

Shipping dimensions (mm) Weight 4.9 kg

Product Code	Description
G747-HAA	12.5 kg Grease Unit >5000psi



HIGH PRESSURE 20KG GREASE PUMP >5000PSI

Shipping dimensions (mm) Weight kg

Product Code	Description
PI020-AAA	High Pressure 20kg Grease Pump >5000psi

MEDIUM PRESSURE 50KG GREASE PUMP >250PSI

Shipping dimensions (mm) Weight kg

Product Code	Description
PI032-AAA	Medium Pressure 50kg Grease Pump >250psi

General Equipment



2105 FUEL RETRIEVAL UNIT

For the Safe and easy emptying / filling of fuel from vehicles.
 Two integral flash arrester filters of 400 microns.
 Fully antistatic incorporating earth leads and fuel grade hose.
 Will pump most mixtures of fuel at 30 - 40 litres per minute.
 95 Ltr tank capacity.
 Locking valve to prevent unauthorised use and accidental discharge.

Shipping dimensions (mm) 1300 x 600 x 560 Weight 29 kg

Product Code	Description
2105-010	Fuel Retrieval Unit c/w Rotary Pump



2167 BUNDED DISPENSING CABINET

Cabinet designed for the storage and dispensing from two 60 Ltr drums in accordance with the requirements of Health and Safety Regulations.
 Integral 85 Ltr bund to hold drum contents if punctured.
 Can accommodate hand operated or Air operated pumps as required.
 Simple to fit brackets enable the mounting of hose reels for remote dispensing.

Shipping dimensions of Cabinet only (mm) 1020 x 1110 x 545 Weight 80.5 kg

Product Code	Description
2167-002	Bunded Dispensing Cabinet



60 LTR DRUM LIFT TROLLEY FOR USE WITH BUNDED CABINET

Shipping dimensions (mm) 1200 x 410 x 390 Weight 7.5 kg

Product Code	Description
2169-001	60 Ltr Drum Lift Trolley for use with bunded cabinet



NOTE: When shipped with 2167 Bunded Dispensing Cabinet this Trolley fits inside the cabinet.

General Equipment



208 LTR DRUM BUND

For the safe storage of 208 Ltr drums in accordance with the requirements of the Health and Safety Regulations.

Shipping dimensions (mm) 830 x 820 x 475 Weight 65 kg

Product Code	Description
2115-001	Single Drum Bund

LOW PROFILE DRUM BUNDS

For the safe storage of 208 Ltr drums in accordance with the requirements of the Health and Safety Regulations.

Product Code	Description
2115-004	Double Low Profile Drum Bund
2115-005	Triple Low Profile Drum Bund



30 LTR DRUM BUND

For the safe storage of two 20 / 30 litre drums in accordance with the requirements of the Health and Safety Regulations.

Shipping dimensions (mm) 705 x 455 x 115 Weight 10.5 kg

Product Code	Description
2115-002	Double Drum Bund



SPILLAGE CONTROL PRODUCTS

A comprehensive range of spillage control products are available to contain minor and major incidents. All products are illustrated on a separate leaflet. Contact Sales department for further details.

General Equipment



FLOOR STANDING PUMP POST

Shipping dimensions (mm) 1240 x 316 x 300 Weight 22.5 kg

Product Code	Description
2139-002	Floor Standing Pump Post (pump not included)



STEEL KEG LIDS & FOLLOWER PLATES

Steel keg lids with 2" BSP fitting and three fixing screws. Available for 12.5kg, 20kg, 50kg and 180kg. Steel and rubber follower plates with pull ring. Available for 12.5kg, 20kg, 50kg and 180kg. Lids are available in various colours.



877 MOBILE OIL DISPENSER

Available in various forms and colours. Single Tank of 200 Ltrs capacity. Two Tanks of 95 Ltrs each capacity (as illustrated). Three Tanks of 60 Ltrs each capacity. Four Tanks of 50 Ltrs each capacity. 2" BSP pump mounting collar, in each tank, suitable for most types of pump fitment. Lockable filler cap.

Shipping dimensions (mm) 1055 x 875 x 635 Weight 40 to 72 kg



2201 MOBILE OIL DISPENSER - 24 LTR

Suitable for storing and transporting most types of gear and lubricating oils. Heavy duty all steel construction. Complete with pump, hose and on/off tap for dispensing directly into hard to reach places. Available in various colours.

Shipping dimensions (mm) 935 x 430 x 312 Weight 15 kg

Product Code	Description
2201-001	Mobile Oil Dispenser - 24 Ltr



CARTRIDGE GREASE GUN

Heavy duty lever action cartridge grease gun. 400 gram capacity. Bulk fill capacity 480 grams. Complete with rigid lance and hydraulic grease nozzle.

Pipe Fittings



BALL VALVES

Product Code	Description
06R20001	1/4" BSP (Plated Brass)
06R20009	1/2" BSP (Plated Brass)
06R20010	1/2" BSP male / female Threads (Plated Brass)
06R20105	3/4" BSP Full Port Short Handle
06R20067	1" BSP Full Port Short Handle
06R20018	1/4" BSP (female threads)
06R20059	1/2" BSP (female threads)
06R20038	3/4" BSP (female threads)
06R20002	1" BSP (female threads)
06R20104	1.5" BSP (female threads)
06R20091	2" BSP (female threads)
06925-E3	3/4" BSP Plastic Barrel Tap
06R20099	2" BSP Plastic Barrel Tap

QUICK RELEASE COUPLINGS

Product Code	Description
06R20013	1/4" BSP Carrier (Plated Steel)
06R20014	1/4" BSP Probe (Plated Steel)
06R20114	1/2" BSP Carrier (Plated Steel)
06R20052	1/2" BSP Probe (Plated Steel)
06R20016	3/4" BSP Carrier (Plated Steel)
06R20017	3/4" BSP Probe (Plated Steel)

Y STRAINERS

Product Code	Description
06R20117	1/2" BSP Bronze
06R20077	3/4" BSP Bronze

CONE SEAT FITTINGS

Product Code	Description
06R20023	1/2" BSP x 1/2" BSPT male Adapter (Plated Steel)
06R20041	1/2" BSP male Adapter (Plated Steel)
06R20021	3/4" BSP male Adapter (Plated Steel)
06R20042	3/4" BSP x 3/4" BSPT male Adapter (Plated Steel)
06R20123	1/4" BSP x 1/8" BSP male Reducer (Plated Steel)
06R20063	5/8" BSP x 1/2" BSP male Reducer (Plated Steel)
06R20022	3/4" BSP x 1/2" BSP male Reducer (Plated Steel)
06R20062	3/4" BSP x 5/8" BSP male Reducer (Plated Steel)
06R20083	1" BSP x 3/4" BSP male Reducer (Plated Steel)
06R01009	1/4" Dowty Seal
06R01008	1/2" Dowty Seal
06R01007	3/4" Dowty Seal
06R01013	1" Dowty Seal

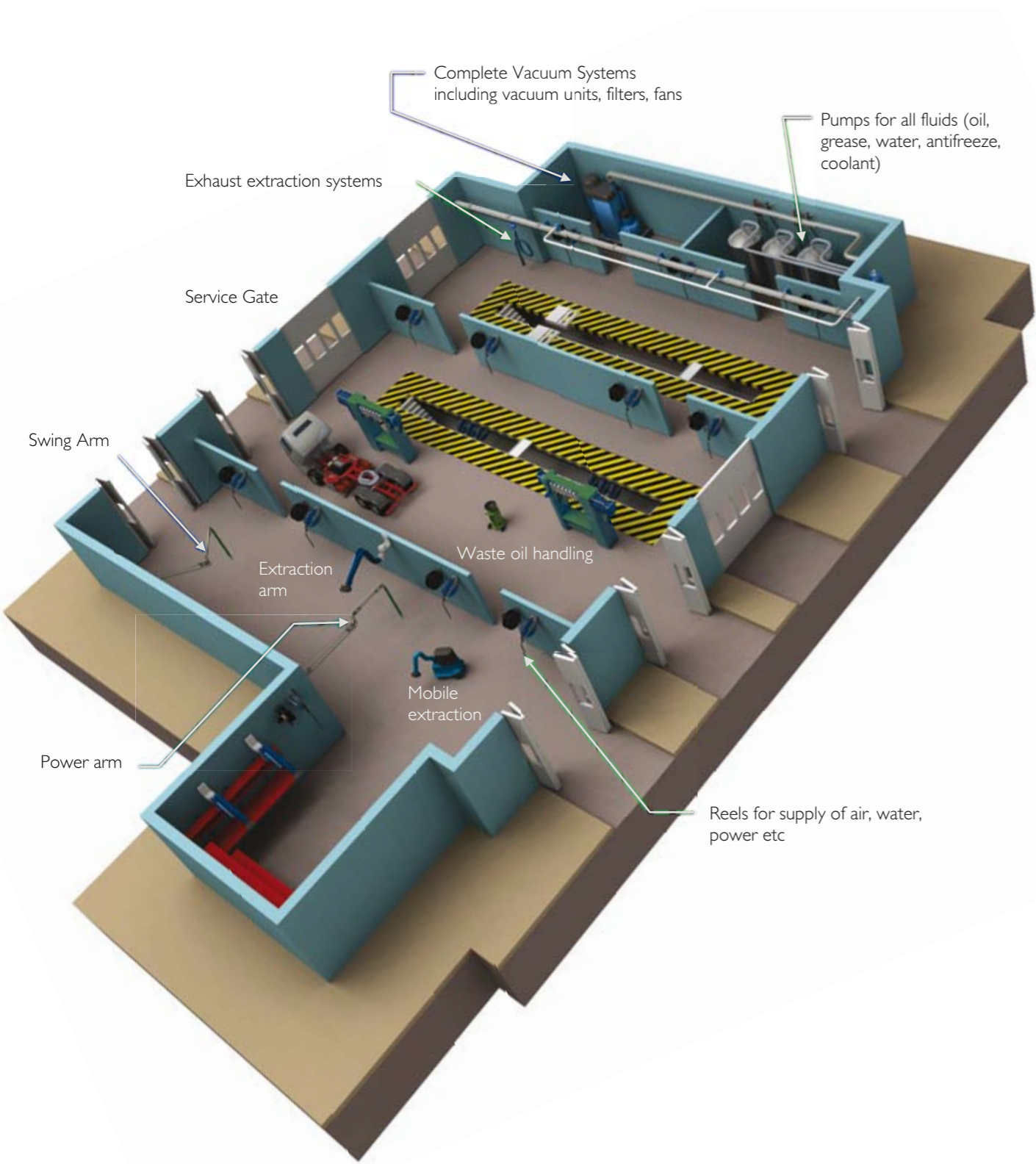

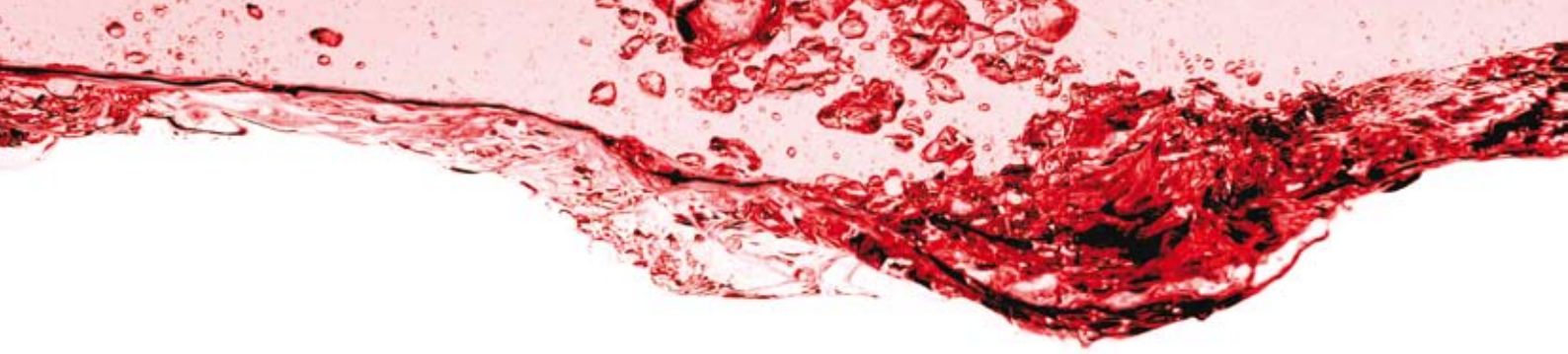

10-12 Meadowbrook Park, Station Road, Halfway, Sheffield S20 3PJ, England
Tel: **+44 (0)114 248 4882** Fax: **+44 (0)114 248 9142** email: sales@hillpumps.com

www.hillpumps.com